



CHANGING SPACES – CREATING CHOICE

abo]space abo]sign abo]clear



TABLE OF CONTENTS

01

About us

We have been creating
new spaces since 1983

02

abo]space abo]clear

The many possibilities of
our partition wall systems

03

abo]space

The technical details
and floor plans

04

References

More flexibility through
movable walls

05

abo]sign

Movable space solutions
with acoustic partition walls

06

Service

No matter what happens,
we are there for you



01



abo]part

Market leader and father of partition walls

Movable walls since 1983

We are a modern and innovative industrial company in Ammerland near Oldenburg. With over 100 employees, we produce and assemble movable partition walls and glass partitions both nationally and internationally in over 20 countries. The production facility, which is located at the same site as the distribution centre, manufactures the movable walls in made-to-order units, precisely tailored to each customer's requirements. This is how custom full solutions of the highest quality are created with the label „Made in Germany“.

Through the years, experience and traditional construction methods have perfected our movable walls. Thus, today we can say: Everything is possible. The combination of unit types, materials, surfaces and colours alone offers an entire world of possibilities.

Every space has its own atmosphere. Step inside and feel it.

SPACE MANAGEMENT USING PARTITION WALLS



Space management through partition walls

Today it is more important than ever to create added value for investors as well as for residents or users of the property within the building or architectural design. Functional and energy aspects are just as important as optimal room acoustics. Maximum flexibility is an added bonus, especially in public facilities and buildings. That is why you should design with abopart – the specialists in movable partition walls with over 35 years of experience – worldwide.

The art of change

Flexibility is a big word. If there are true experts in this area, then they are children. They want to design, build and rebuild from an early age. Fortunately, we at abopart have managed to retain these desires. So it is no coincidence that our movable walls are as well-known as they are popular on the international stage.

Be it a hotel, concert hall, museum, trade fair or multi-purpose hall - every building gains potential as soon as the floor plan can be changed flexibly. And what applies to buildings also applies to mobile properties such as modern cruise ships.

Room experience – experience room

They are the same height as the room, movable and absorb sound. With abopart movable walls, rooms can be used optimally. What today is still a ballroom can be easily converted into a conference room, training room or social room at any time. Make one room into three. The best way to meet all customer requirements.

Discover your own space. It is a game where there are only winners. And the wall design? The following also applies here: Everything is possible. On the next double page you will get a small insight into the variety of our products.



02

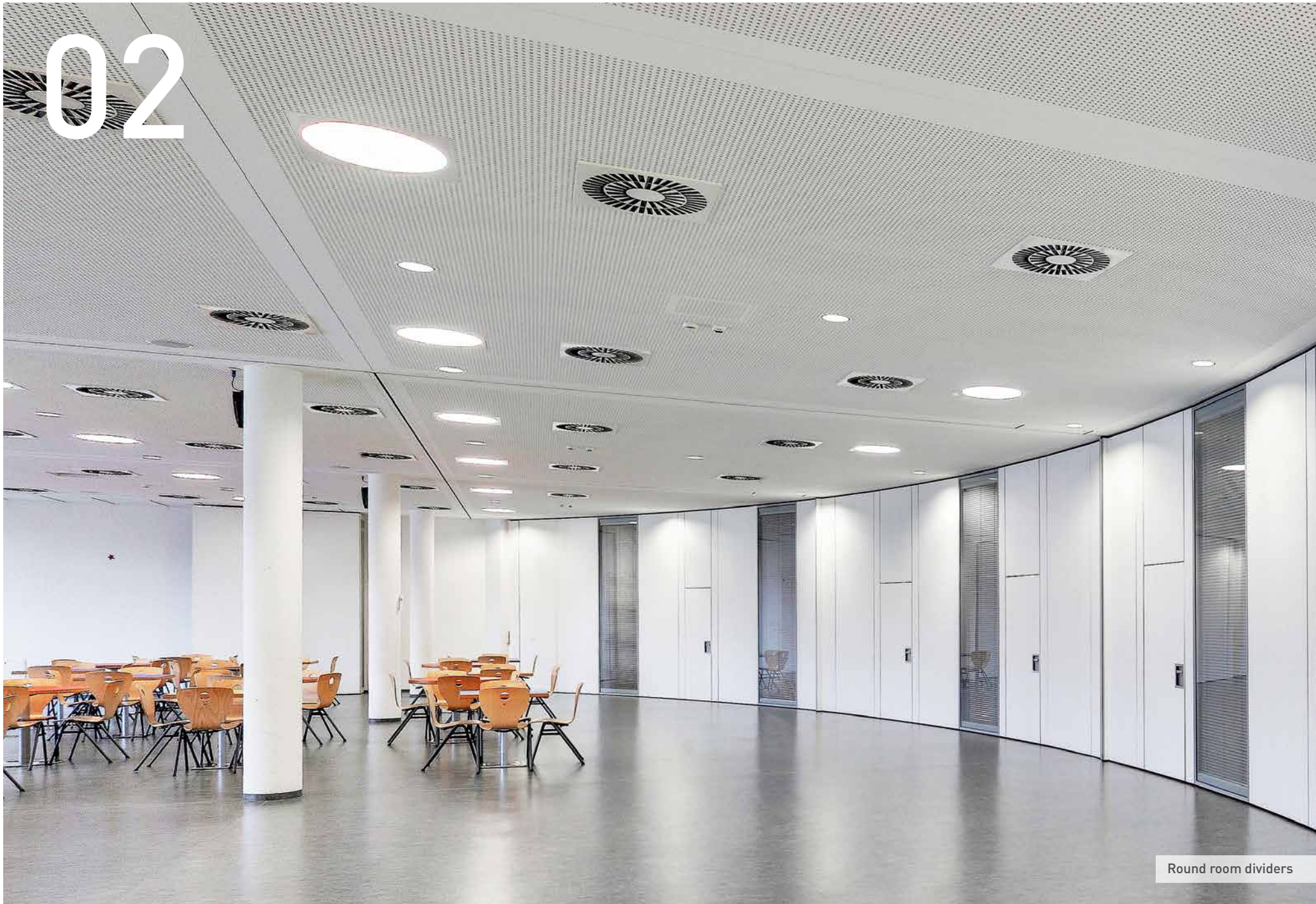

Round room dividers

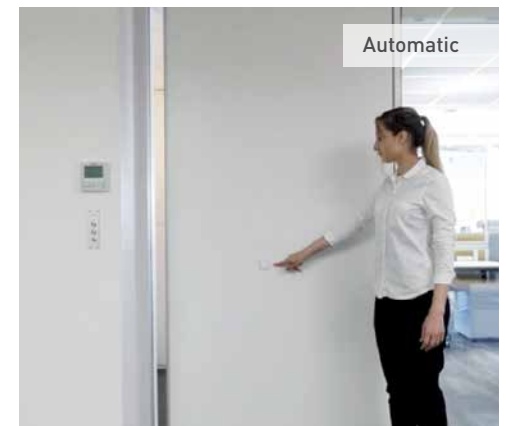

STRUCTURE OF A PARTITION WALL

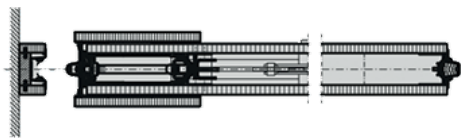

1 Wall rail



2 Telescopic panel



3 Pass door unit

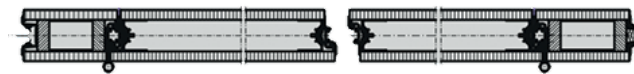

4 Double pass door panel

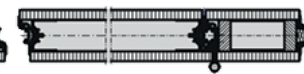

5 Double leaf



6 Standard glass unit

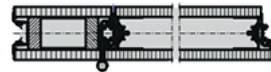

7 Pass door unit

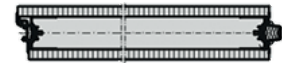

8 Door connection unit



9 Wall connector

THE STANDARD UNIT

Nearly anything is possible

They are floor-to-ceiling, movable and sound absorbing up to a height of 15 m and a maximum width of 1.20 m. With abopart movable walls, rooms can be used optimally. Manual operation, semi-automatic and fully automatically controlled via the touch panel – anything is possible.

Scissor mechanism

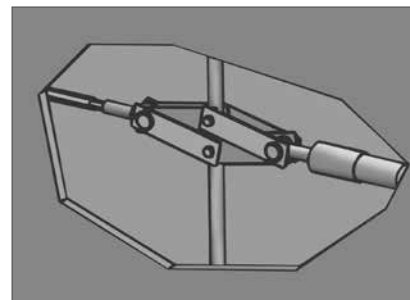

The sealing strip can be slid out at the top and bottom



THE TELESCOPIC PANEL

It could not be simpler

The abopart telescopic panel completes the enclosure of the room. The externally mounted panels ensure maximum sound insulation up to R_wP 60dB, even when the space is enclosed. Manual, semi-automatic with LED monitoring or fully automatic – we will find the best solution for your room.

The sealing strip can be pulled out at the top

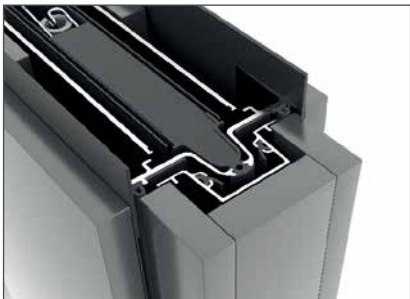

Strip with mechanism



THE TELESCOPIC PANEL

The units

No matter what requirements you have for your rooms, we will find the right solution with our system. Sound insulation, design and function, separate or combined, we have the right connection.



■ Telescopic panel 100 M

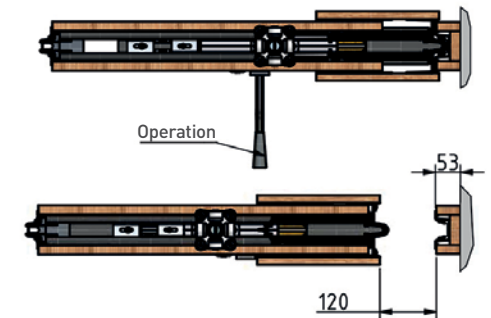

■ Telescopic panel with surface-flush telescopic part

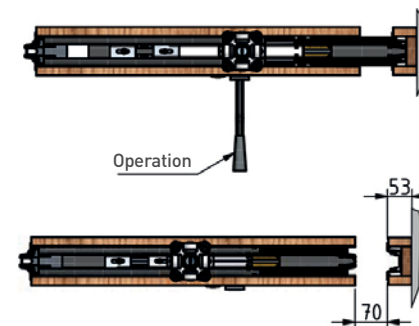

■ Telescopic panel with internal telescopic component

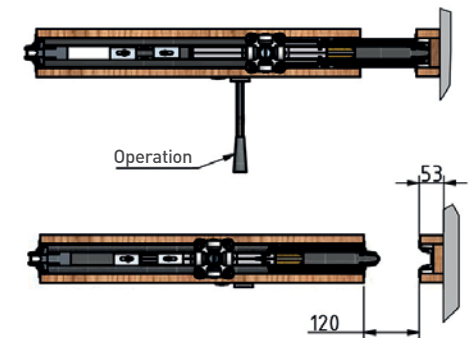

THE TELESCOPIC GLASS PANEL

Telescopic glass unit abo]clear

With our abo]clear sound-absorbing glass units we are able to bring light into your rooms. abo]clear glass units are semi-automatic and therefore very easy to use. Delicate profiles – only 33 mm – mean maximum transparency.

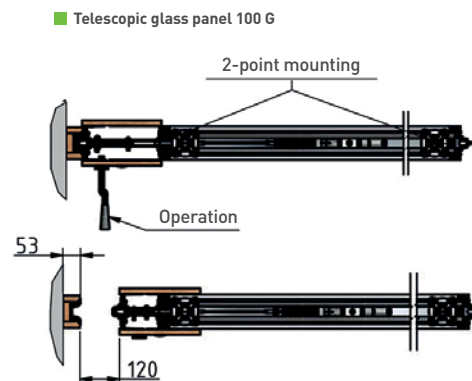
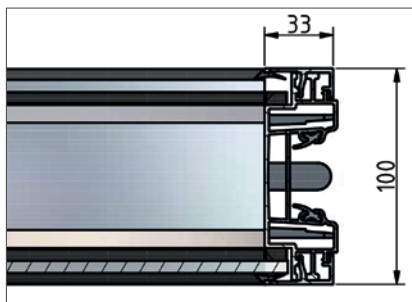

The door in the wall

The door unit for quick and easy passage through the closed movable wall. It's all or nothing! Therefore abo-part doors are single-leaf or double-leaf sound-tested up to R_wP 51 dB, in two standard widths, but also in custom sizes.

In addition to sound insulation and maximum comfort, access doors from abopart can also be used as emergency exits.



Handle plate



DOOR DETAILS

DOOR DETAILS

Technical details, dimension and floor plan details at a glance.

Contact us, we are happy to assist you and have a suitable solution.

1. Access door unit

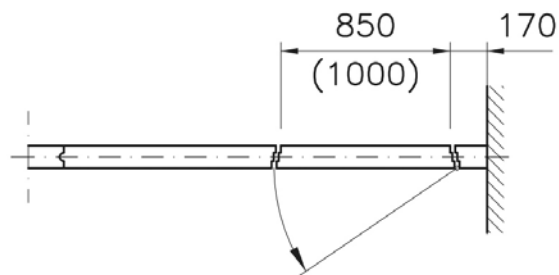

2. Pass door unit, double-leaf (SE2)

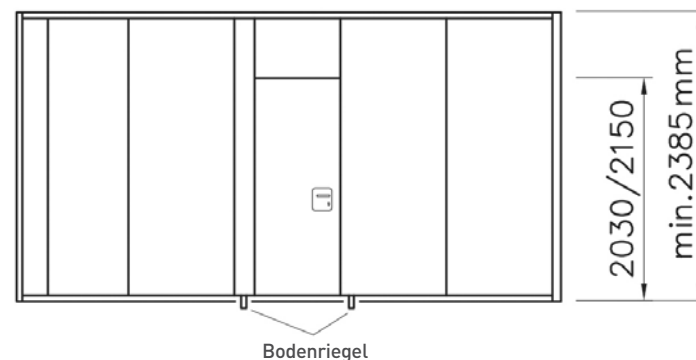
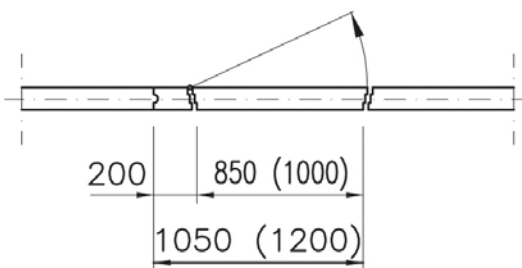

3. Pass door unit, single-leaf (SE1)

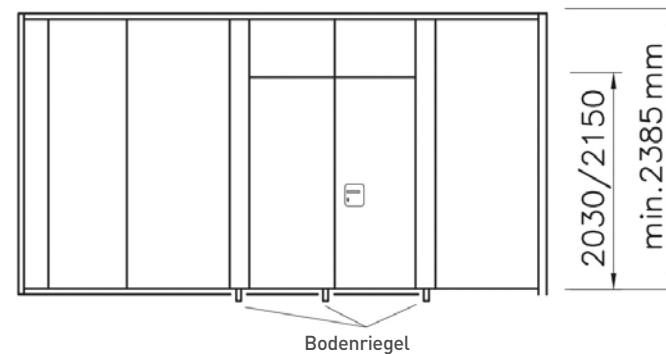
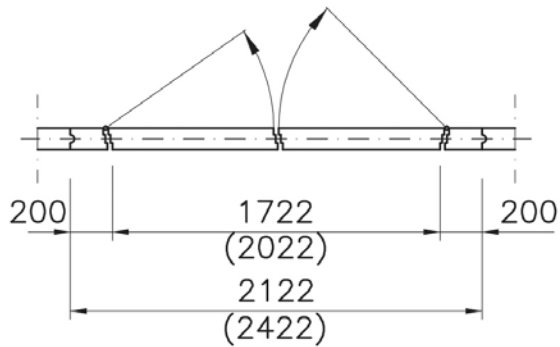

Floor bushing V2a D=25 mm

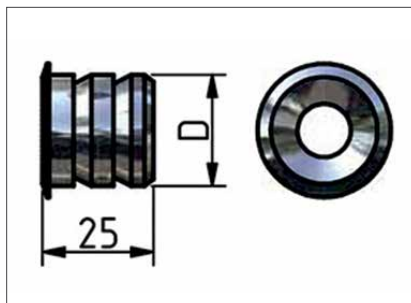

Floor recess plate V2a D=65 mm

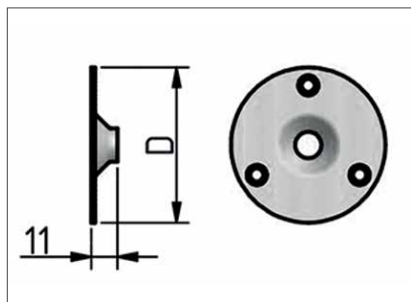

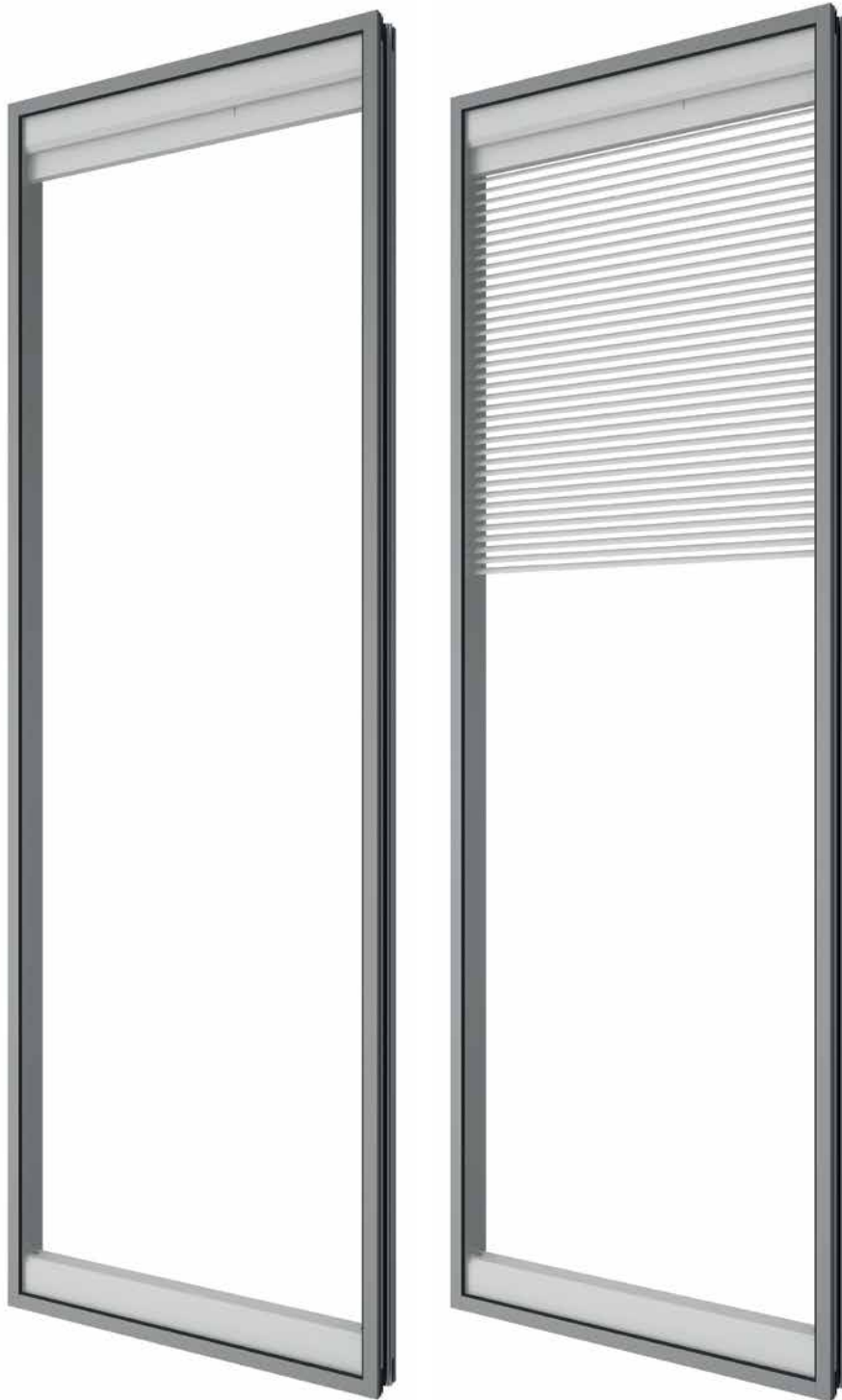

THE GLASS UNIT

Glass panel abo]clear with interior blind

Our abo]clear glass unit can also be fitted with an integrated blind. The blind is electric and can be raised or lowered at the touch of a button. Transparency, sound insulation, sun protection and privacy all provided by one unit. For easy assembly and disassembly, the connection strips extend electrically against the ceiling and the floor. abo]clear at the touch of a button.

Transparency, privacy, smoke proofing and sound proofing up to RwP 54 dB can all come together.

Drawing

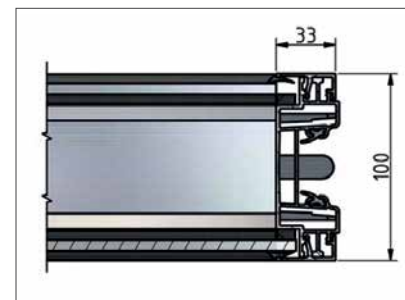

Contacts



Rail systems

Our rail systems are industrially manufactured, welded and then finished with powder coating. The aluminium or steel rails which act as the ceiling mounts, and the maintenance-free, ball-bearing rollers, ensure that the individual units can be moved around easily.

The special roller system makes operation very easy and smooth. On top of that, it is low-maintenance and durable.



Powder-coated rail RAL 9016

■ with support bracket

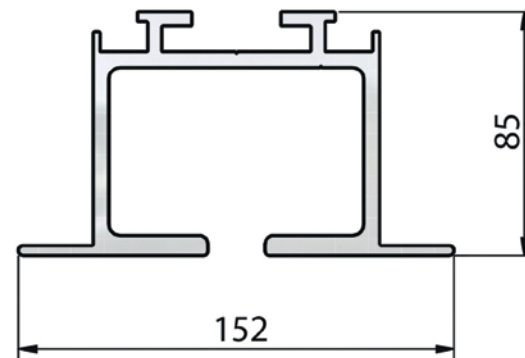

■ without support bracket

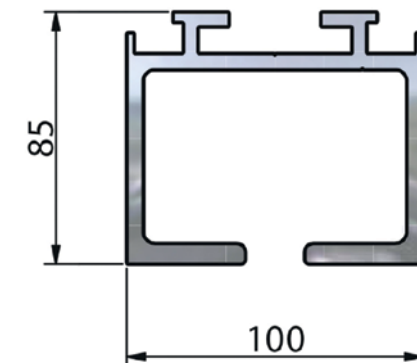

03

TECHNICAL STRUCTURE

Design and structure

The acoustic connection to your premises is made by our sealing strip to the floor and to our ceiling rail. On the sides, our wall connections and the telescopic panel form the room partition.

Our sales team will be happy to provide you with information. Good planning ensures excellent results, such as at Stiebel Eltron in Holzminden. In addition to the DGNB platinum certification, the client achieved a sound insulation of $R'w$ 51dB measured on site.

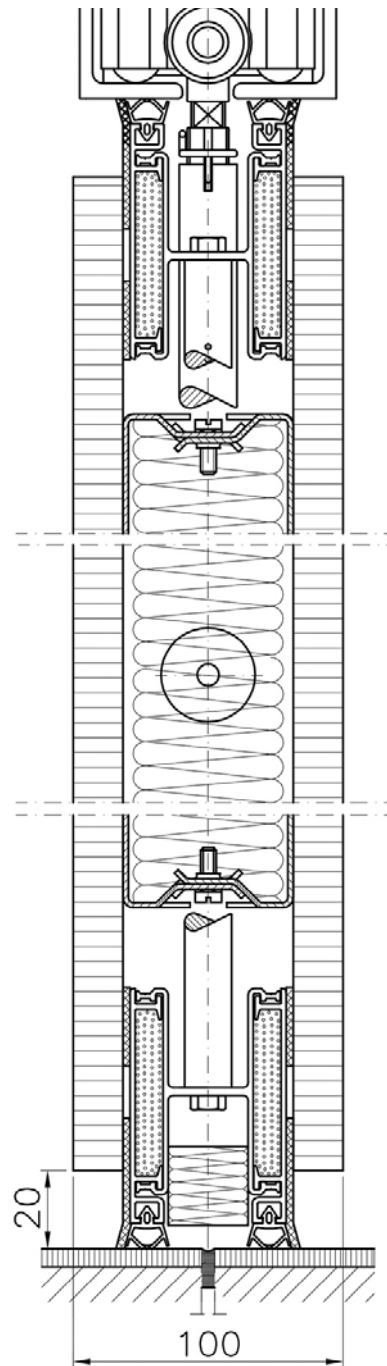
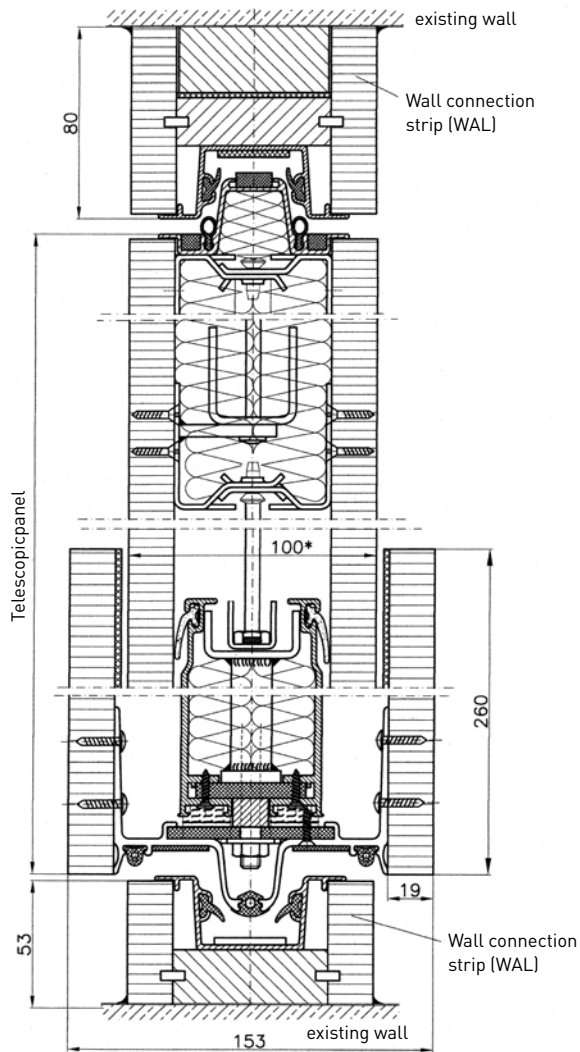

Perfect sound proofing at Stiebel Eltron



THE PARKING CONFIGURATIONS

Parksituationen

To close the movable wall, the individual units, which can be moved independently of each other, are fixed in their final position to save space. They recede completely out of view. Using an on-site boxing system, they can even disappear completely from view.

In addition to seven different standard parking positions, we also offer special custom-made designs to suit your requirements.

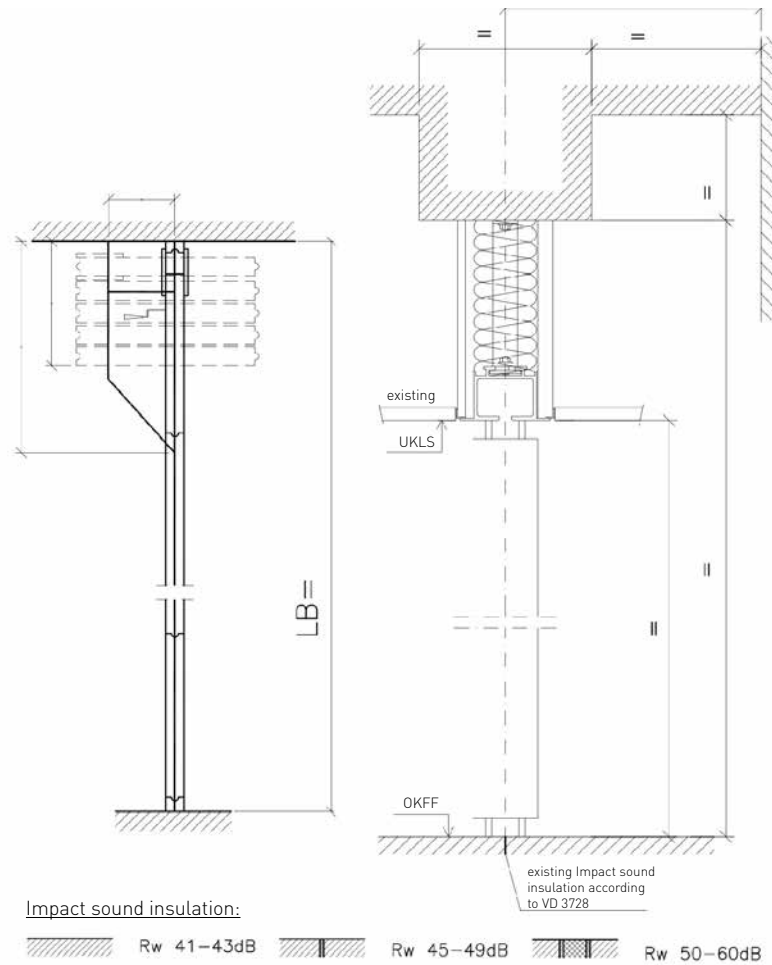

PARKING 1

THE PARKING CONFIGURATIONS



PARKING POSITION 2



PARKING POSITION 3



PARKING POSITION 4

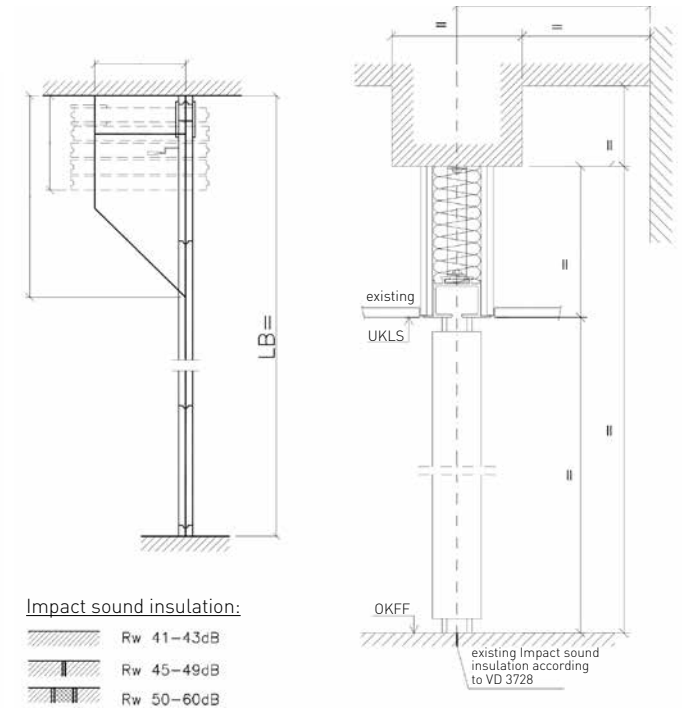
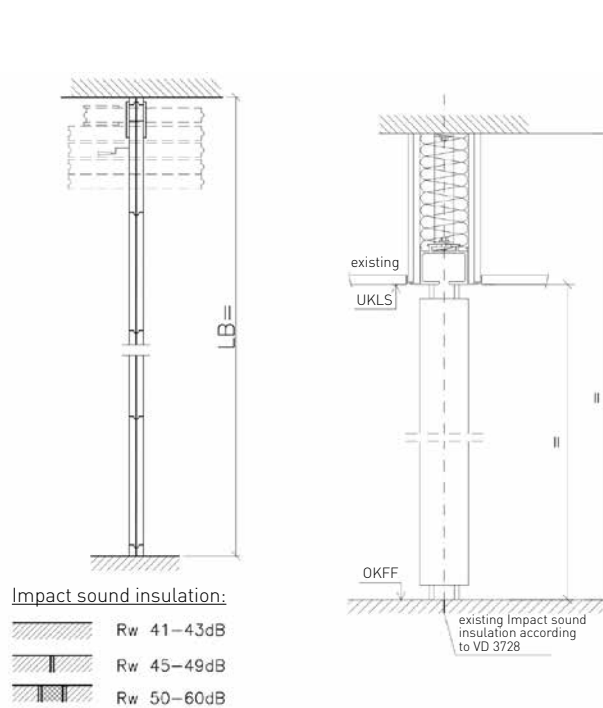
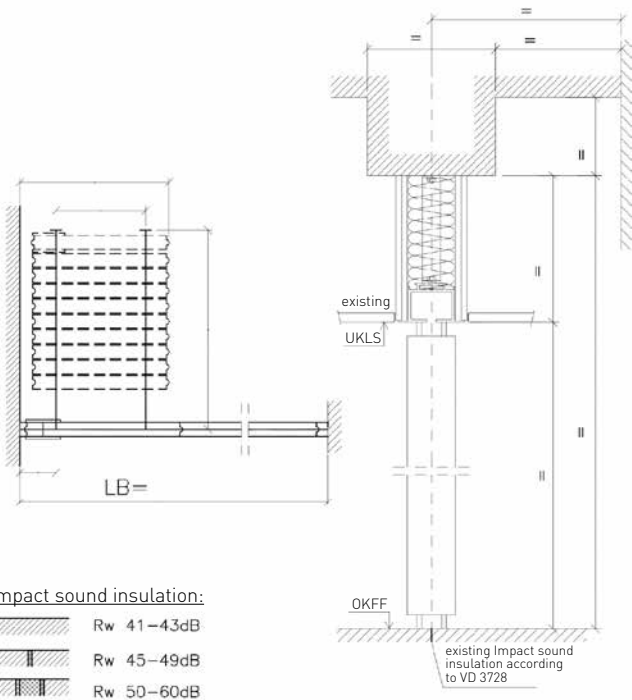

THE PARKING CONFIGURATIONS



PARKING POSITION 5





PARKING POSITION 6



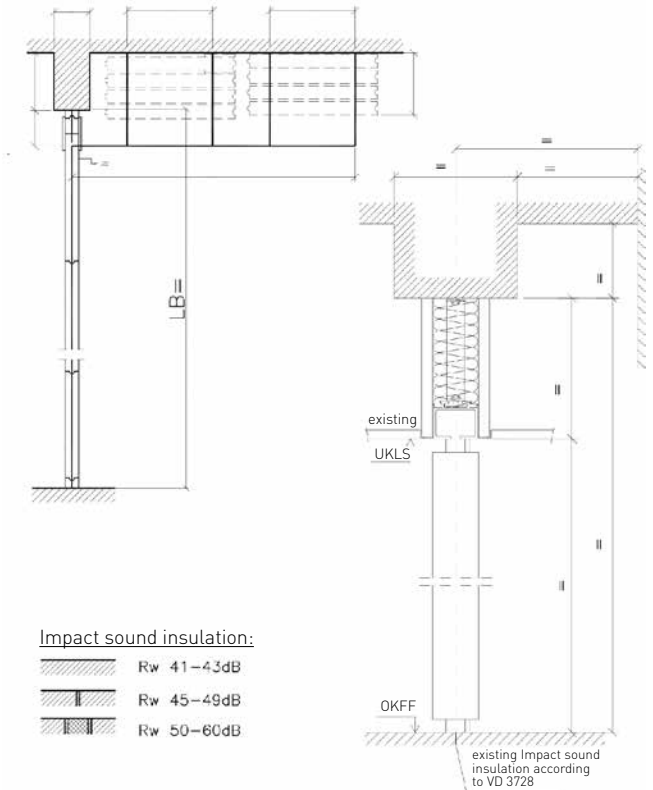
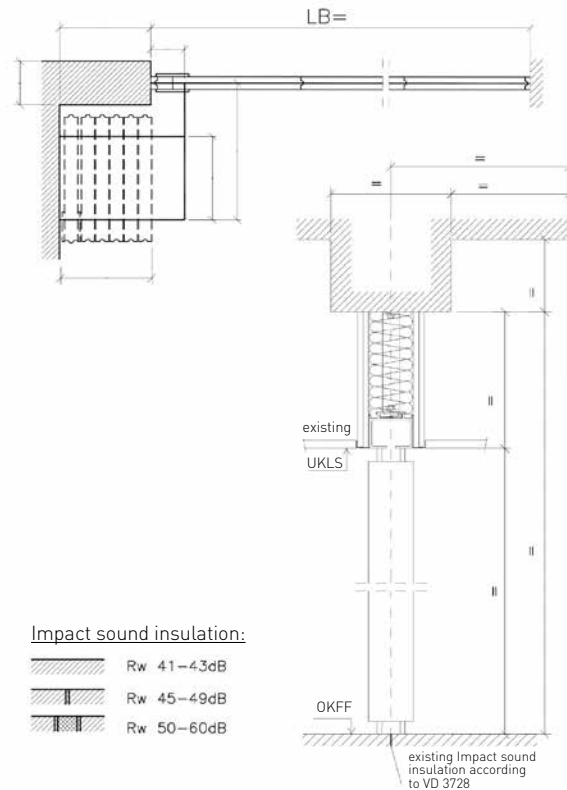
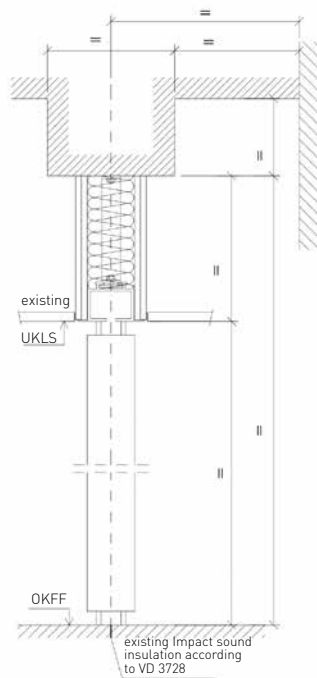
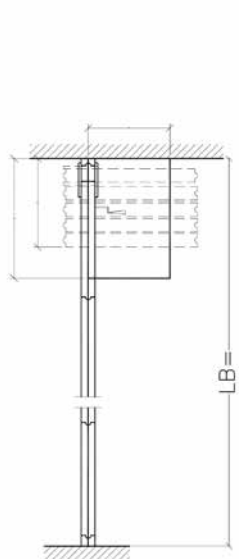

PARKING POSITION 7





Impact sound insulation:

-  Rw 41–43dB
-  Rw 45–49dB
-  Rw 50–60dB

Impact sound insulation:

-  Rw 41–43dB
-  Rw 45–49dB
-  Rw 50–60dB

Impact sound insulation:

-  Rw 41–43dB
-  Rw 45–49dB
-  Rw 50–60dB



Glass units

EXAMPLES FOR FIXING THE TRACKS

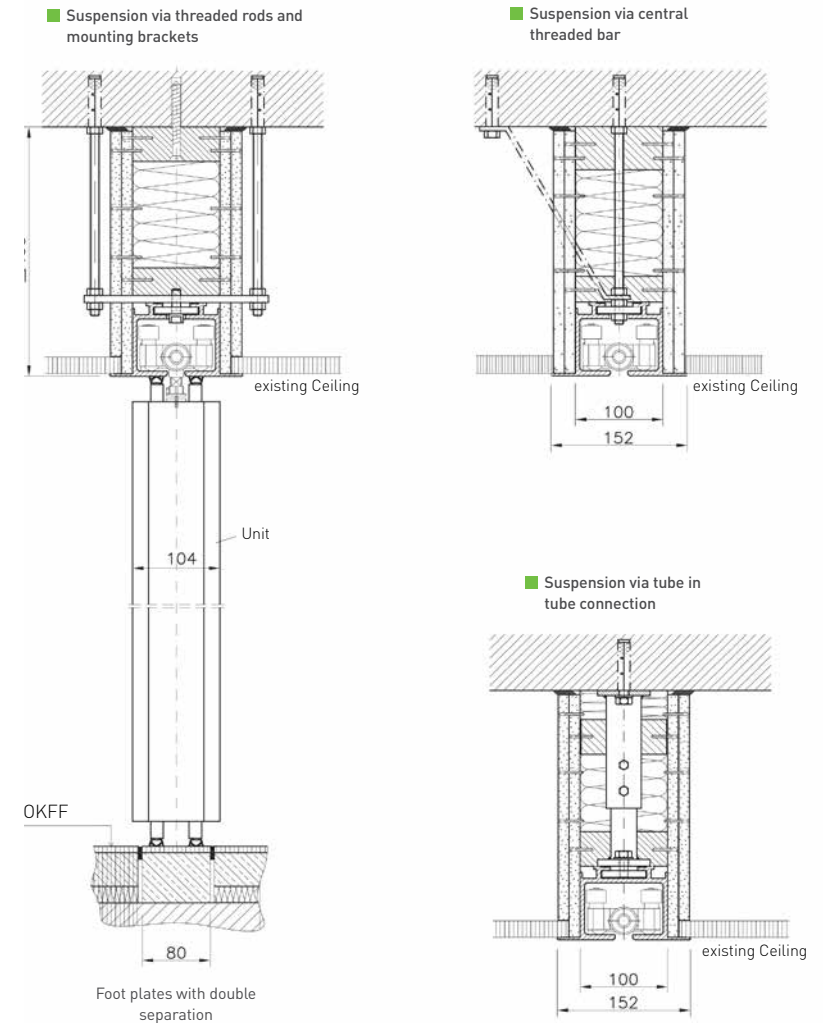
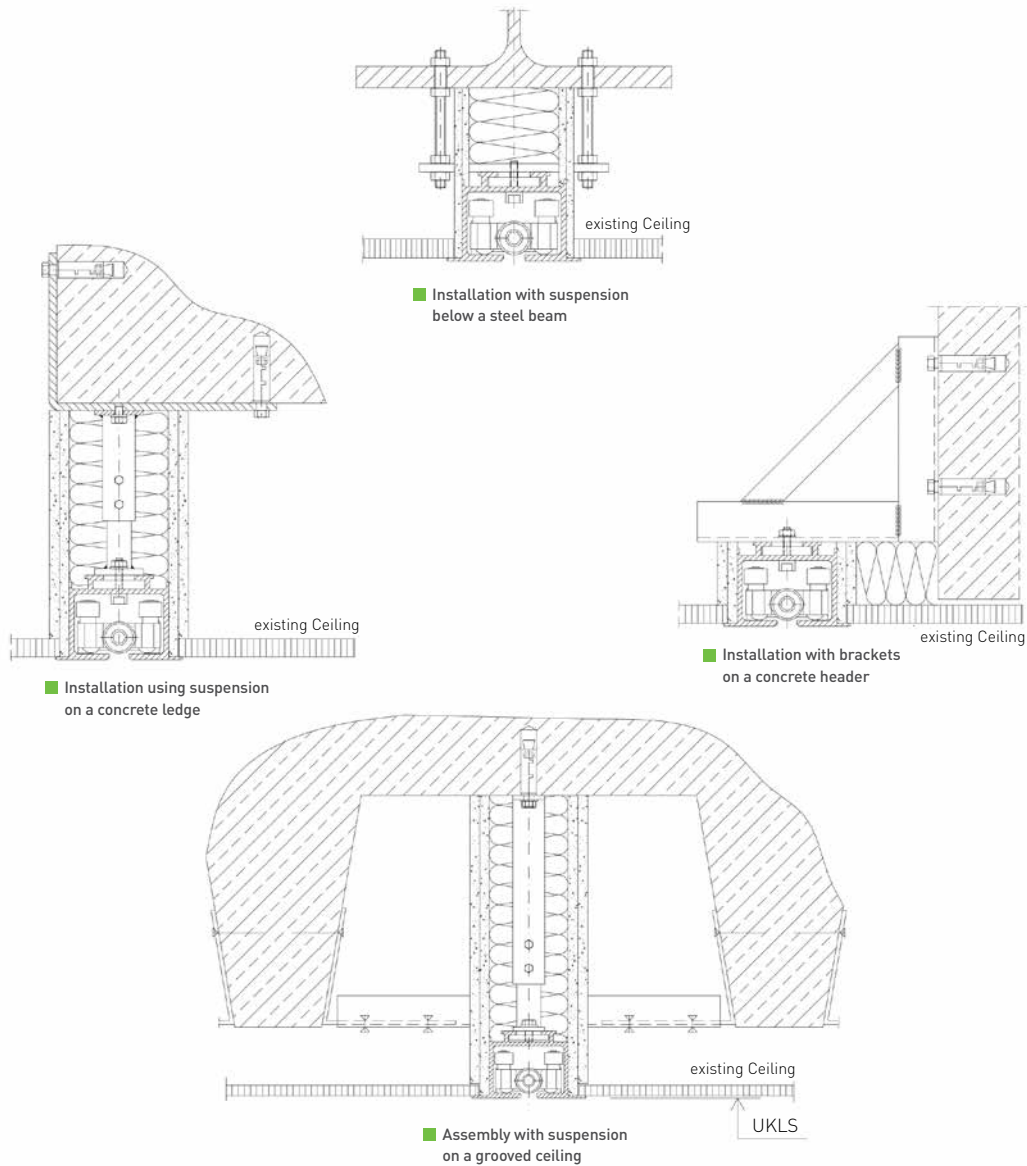

AN UNLIMITED CHOICE OF COLOURS AND SURFACES

Anything you want

You have the choice between warm wood tones, rough, smooth, slotted or perforated finishes. Be it mirrored images, detailed pictures or black and white designs, we've got something for you. The wall can have a picture on it, it can be decorated with digital prints or even with metal designs. All the surfaces listed are available as melamine resin coated board (DBS) or as laminated composite board (HPL). To make it clear: Our range of different products is equal to the number of customers we've served.

The possibilities are practically infinite.

Wood surfaces



STANDARD SURFACE DESIGNS



A 222 Pe ARTIC WEISS
artic white / artic blanc
NCS Code S 0502-G
RAL 9003 / 9016



A 242 Pe UNI WEISS
uni white / uni blanc
NCS Code S 0502-G
RAL 9003 / 9010



A 223 Pe LACKWEISS
white lacquer / vernis blanc
NCS Code S 0500-N
RAL 9010



A 444 Pe ZINNGRAU
tin grey / gris stannique
NCS Code S 4000-N
RAL 7004



A 41 Pe ANTHRAZIT GRAU
anthracite grey / gris anthracite
NCS Code S 7502-R

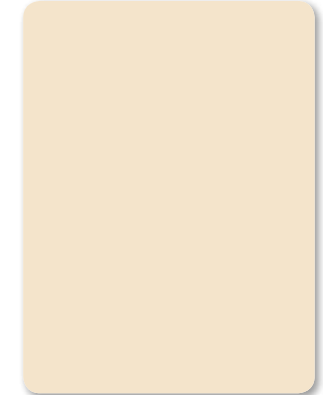

A 320 Pma SAND
sand / sable
NCS Code S 1005-Y30R-N
RAL 1013



A 42 Pe GRAUWEISS
grey white / gris blanc
NCS Code S 1002-Y
RAL 9002



A 402 Pe HELLGRAU
bright grey / gris clair
NCS Code S 2002-G
RAL 7035



A 420 Pe POLARGRAU
polar grey / gris polar
NCS Code S 1500-N
RAL 7047



BU 370 SEMPER BUCHE
semper beech / hêtre semper



EIL 320 LAGO EICHE HELL
lago oak light / chêne lago clair



EIL 730 LAGO EICHE DUNKEL
lago oak dark / chêne lago foncé

The images of the decors are only examples and not color-binding.
Many other decors possible on request. We are happy to send you
original color samples for exact color matching.

04

abo]clear



Garbsen City Library





Otto Bock HealthCare GmbH





CityCube Berlin

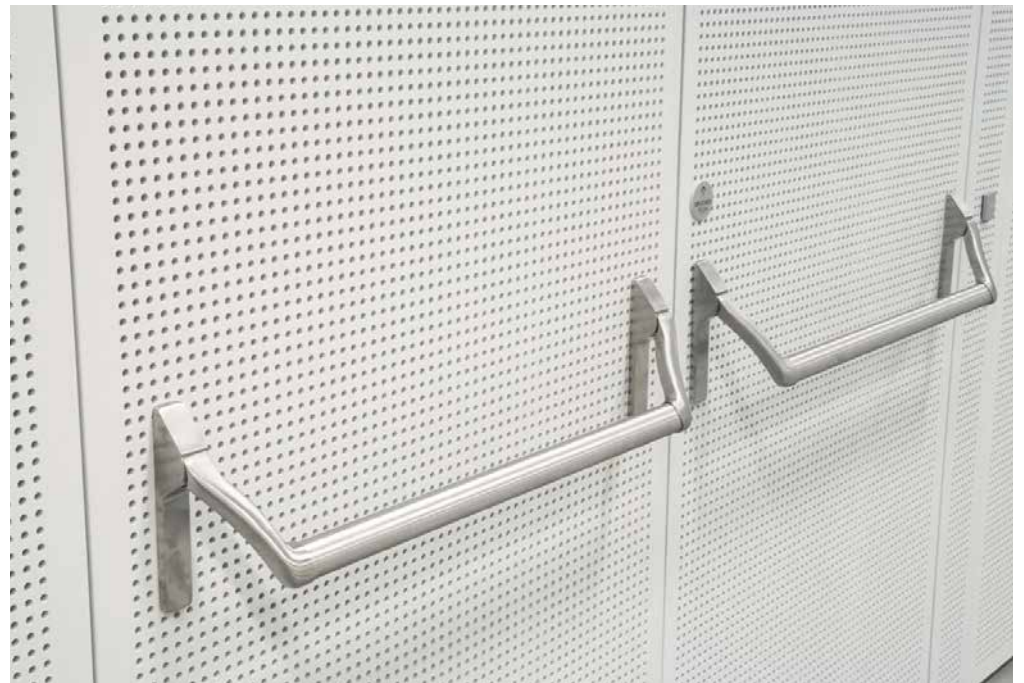

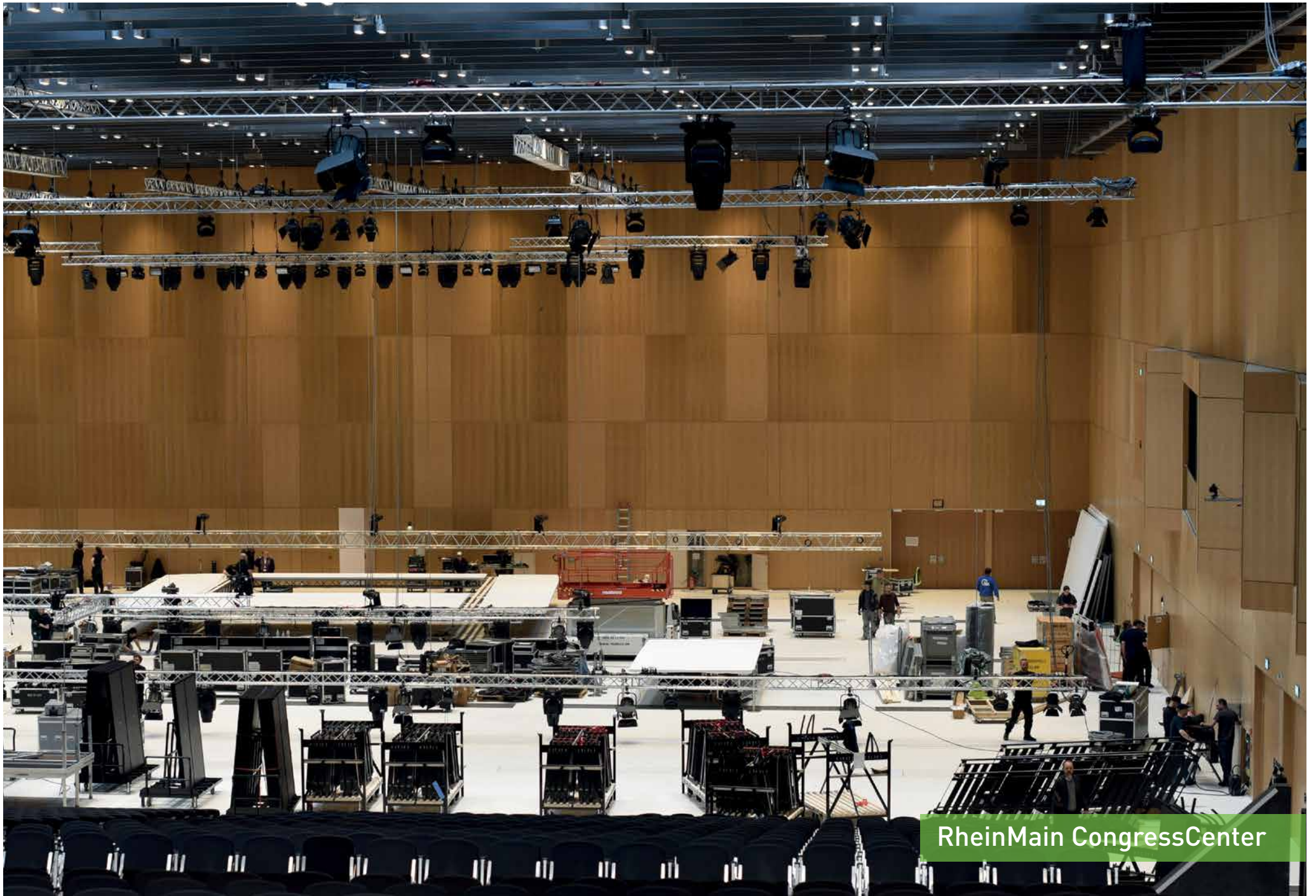

RheinMain CongressCenter

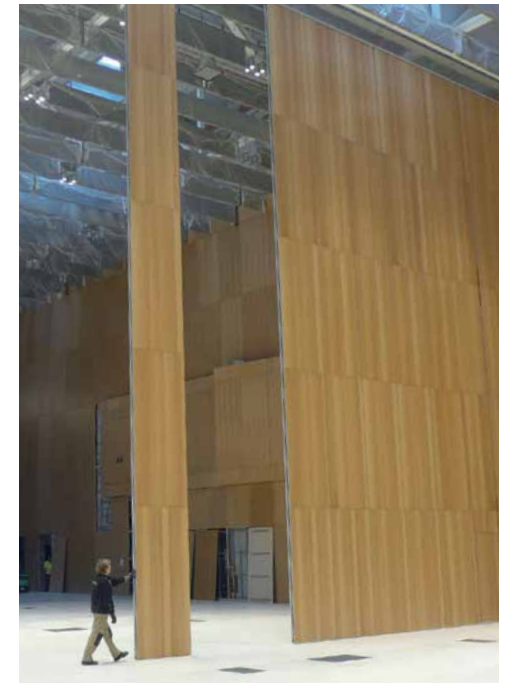
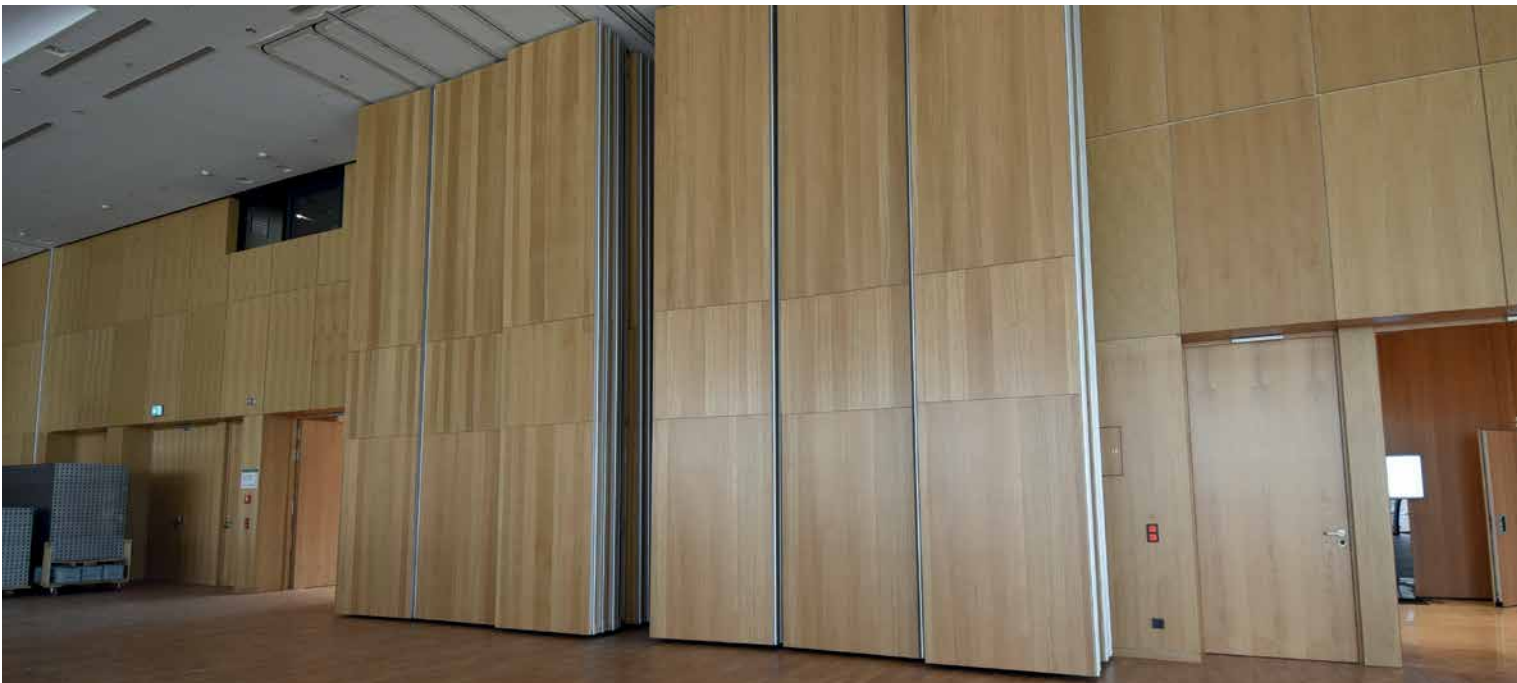
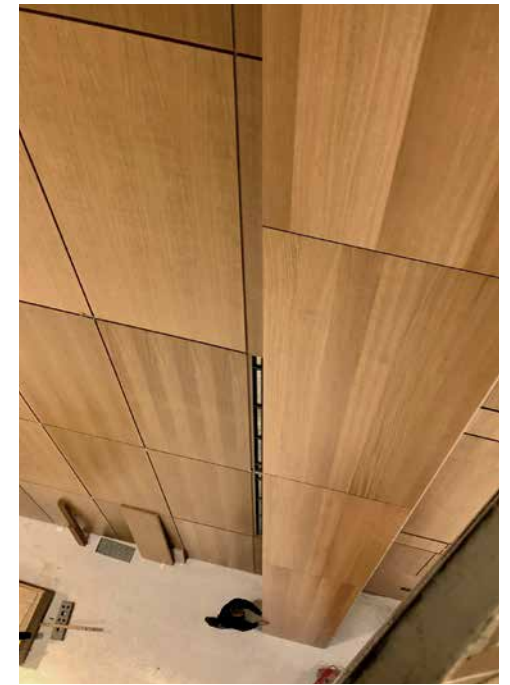

05

MOVABLE ROOM SOLUTIONS WITH
ACOUSTIC PARTITION WALLS



abo]sign

ACOUSTICS FOR ROOM AMBIENCE

WITH EXCELLENT AMBIENT SOUND FOR A PERFECT FINISH

Only the right acoustics can produce the perfect ambient sound. Linear Micro 16 achieves the best results when different sound absorption measurements are made in the same room. Optimal room acoustics are just as important as the functional and energetic aspects. Maximum flexibility is an added bonus, especially in public facilities and buildings. Plus the smooth and soft-gliding rail system that keeps every wall panel safely and securely in place. For years.

YOUR CLIENTS WILL BE DELIGHTED

abopart is developing unique solutions for the industry with its new, special partition wall series **abo]sign**. Space and sound optimisation are paired with unique designs through patterned perforation. The result – perfect harmony.

These movable walls offer many potential applications: You can become limitlessly creative now. In offices, schools, cinemas, lecture halls, hotels, concert halls, event spaces, public institutions and many more **abo]sign** offers a lot of potential for your design ability.

abo]sign



STRUCTURE ACOUSTIC WALL

TREFFEN SIE DIE RICHTIGE WAHL

We have various different materials available in our warehouse. You choose the material thickness, finish and finish individually. For example, we have laminated composite panels, melamine resin-coated chipboard or MDF panels or a laminated composite panel with an internal absorber.

Whichever material you choose, our optimised production lines in our factory guarantee the utmost quality.

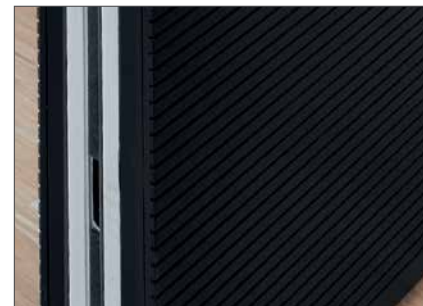
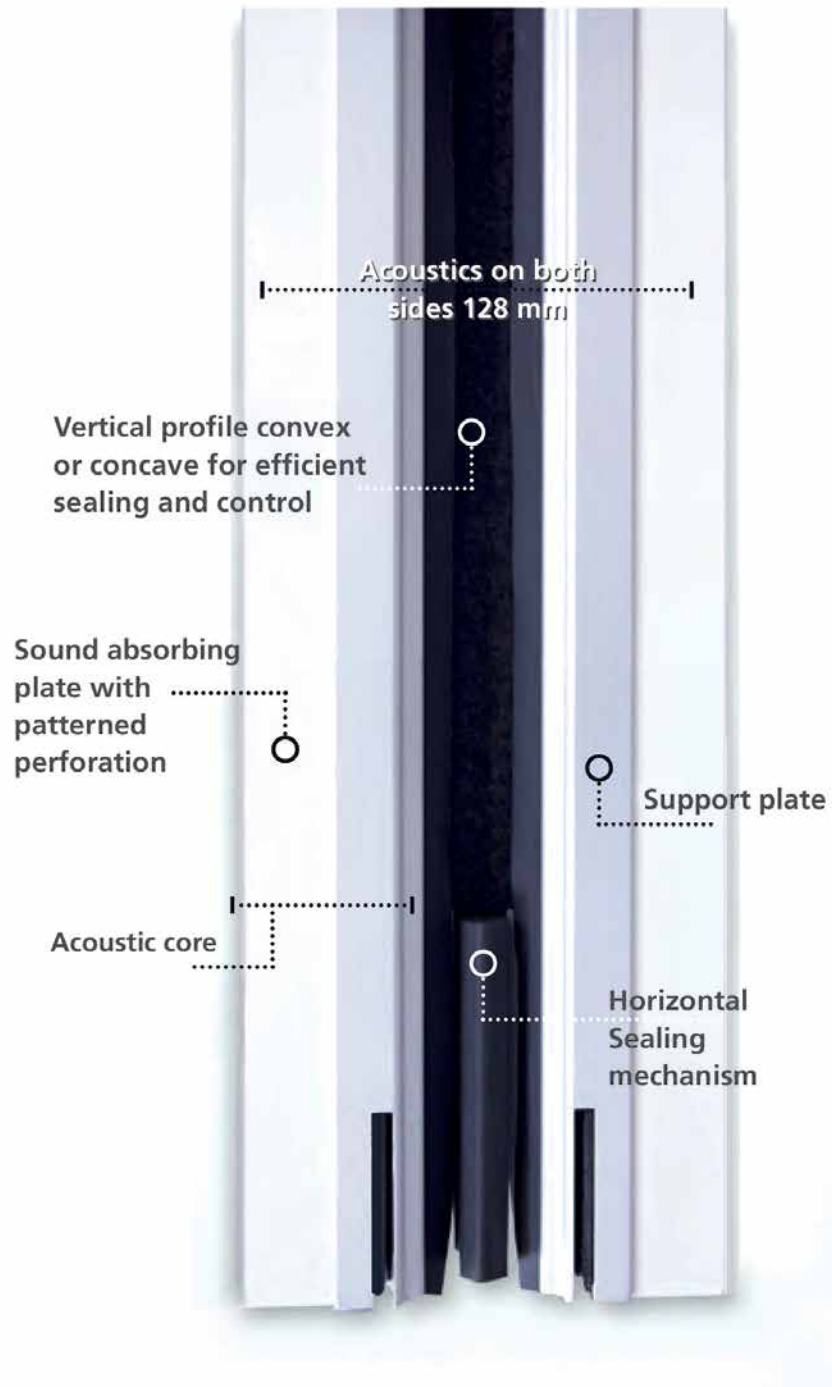

BEST TONES - JUST AS YOU WISH

SILENCE IS BLISS, AND IT AIDS CONCENTRATION

Our partition walls are the perfect solution for noisy rooms. Is your client looking for quiet but doesn't want to clutter their space? Or maybe the sound in a room needs to be optimised so that certain sounds are absorbed and others are accentuated?

Then **abo]sign** is the right place for you, because our sound-absorbing walls not only absorb sound but also improve the overall acoustics of a room.

FREELY SELECTABLE PERFORATION

Modern acoustic wall perforations are now so small and at the same time so effective that even from up close they're imperceptible to the naked eye. Another advantage for functional, modern architecture with partitions from abopart.

No matter whether you need linear or diagonal grids, small or large holes, with or without frames, individually designed hole patterns or even your client's own company logo.

A visual alternative to the classic perforation is the possibility to have your wall modules slotted, thereby creating accents.

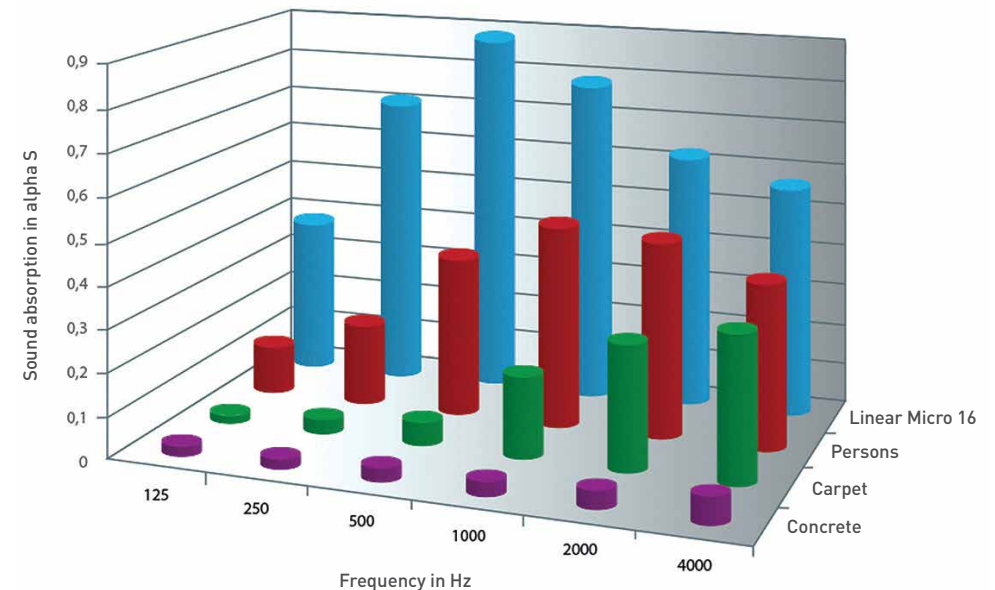

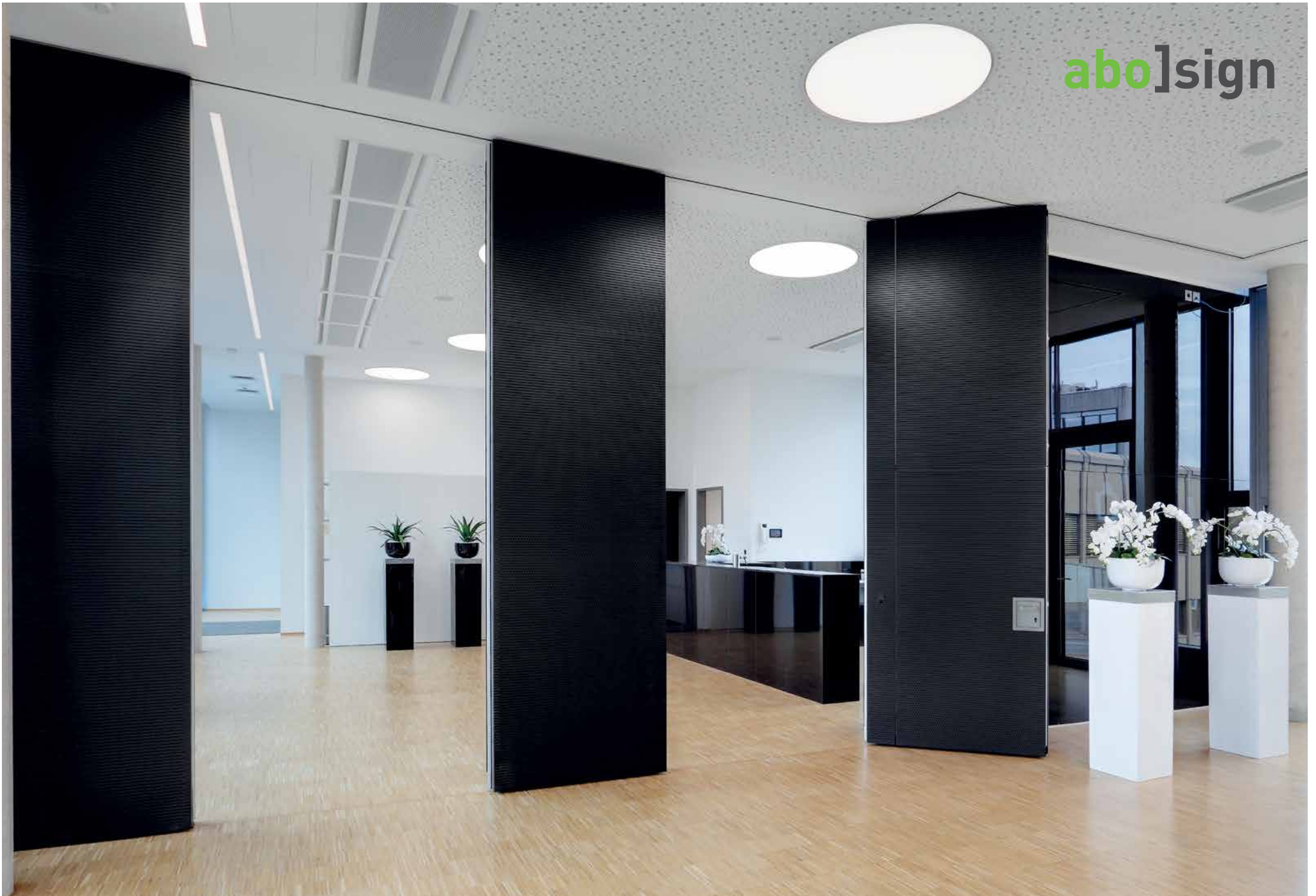

LET THE SOUNDS WASH OVER YOU

FROM OUR CONVINCING REASONS

For 35 years we have been producing partition walls and have been able to convince our customers with tailor-made advice, individual room-in-room solutions, quality products and reliable service.

At abopart, technical documentation and planning support are a matter of course - as a competent partner, we are fully committed to supporting you.

Of course we are also happy to advise you on site to find the best individual solution for you and your client.

We have been certified and reviewed. Only the best is good enough.

WITH CUSTOM PATTERNED PERFORATION

abo]sign makes it possible. With our exclusive and decorative wall designs, we, at abopart, are the only ones who can give your room a completely personal touch. You or your customers' ideas can be found on both sides of the partition walls. You can combine designs or go for a complete panorama. Since our acoustic walls are true allrounders.

Everything is possible with **abo]sign**.

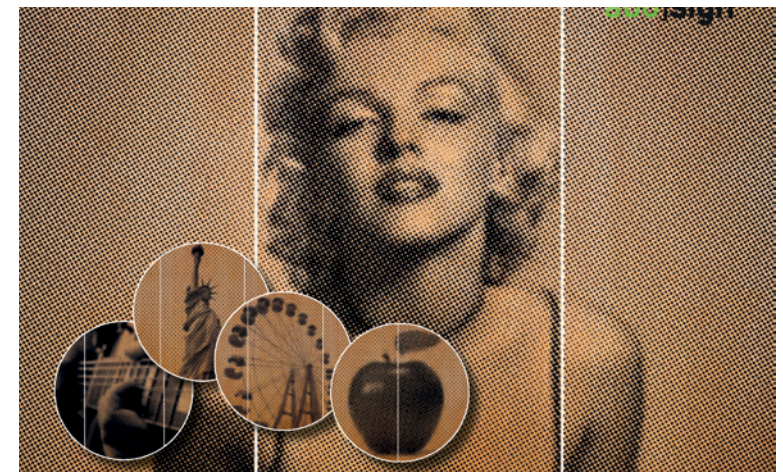

06 YOUR BENEFITS AND POSSIBILITIES

- ▲ Over 40 years of experience
- ▲ In over 20 countries
- ▲ Nationwide coverage sales, consulting and installation
- ▲ Fast service
- ▲ Regular maintenance
- ▲ Owner-operated on a German production site
- ▲ Units up to 15 m in height
- ▲ Manual, semi-automatic or fully automatic operation
- ▲ Manual, semi-automatic or fully automatic operation
- ▲ Industrially manufactured, welded and finished with powder coating railing systems
- ▲ Easy and simple to use
- ▲ Long service life
- ▲ Sound proofing up to RwP 60 dB
- ▲ Sound-proofed doors
- ▲ Individual surface design according to your preferences
- ▲ Approvals in shipbuilding
- ▲ Fire resistance class up to 30 min including doors
- ▲ Entire system flame retardant B1
- ▲ Sales partners all over Germany

OUR SERVICE

SERVICE AND ASSEMBLY OF PRODUCTS

The service offers you a wide range of benefits from a single source. All services are carried out by professionally trained and qualified employees.

The services include:

- Customer service / consulting
- Preparation of installation proposals and offers
- Support from a local sales representative
- Assembly of the products
- Instruction on operation by trained staff
- Regular maintenance
- Repair
- Installation and conversion of existing partition walls
- Assessment of existing partition walls
- Sound insulation measurement

MAINTENANCE AND REPAIR SERVICE

In addition to the production of high-quality movable partitions, another of our strengths is our service. abopart annual maintenance of your partition wall ensures many things, such as:

- value retention
- long service life
- perfect technical condition
- trustworthy, long-lasting usage
- optimum operability
- prevention of high-cost consequential damage



OUR SERVICE HOTLINE

Telephone: +49 4486 9287-99

abopart GmbH & Co. KG
Eichenweg 4
26160 Bad Zwischenahn

Telephone: +49 4486 9287-0
www.abopart.com
mail@abopart.com

